

# PRO CONVERT Audio DX Quick Start Guide

## 1. Packing List

- 1 x Pro Convert Device
- 1 x Quick Start Guide
- 1 x L bracket
- 1 x 5V/2.1A power adapter
- 1 x 4.4mm to Dual XLR Male Cable
- 1 x 4.4mm to Dual XLR Female Cable

## 2. Interfaces and indicators

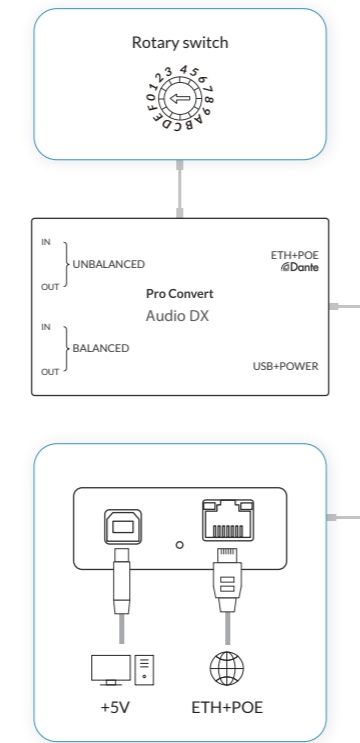
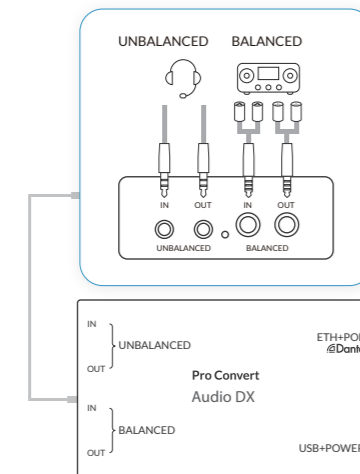

## 3. Get started

### 1. Connect cables.

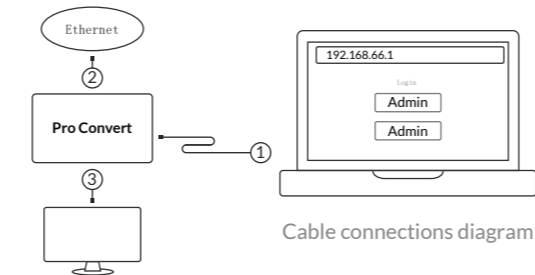

- 1 Connect the device to your computer using the USB cable. It provides USB Network and USB AUDIO IN/OUT.
- 2 Connect the device to the Ethernet network with an Ethernet cable. It provides Ethernet and AoIP codecs - NDI, SRT, RTSP and Dante.
- 3 Connect analog audio, including 3.5mm unbalanced and 4.4mm balanced IN/OUT.

### 2. Log in to the Web GUI.

- 1 Type the USB NET IP address 192.168.66.1 in your web browser.
- 2 Log in with the default case-sensitive username and password (both Admin). You are suggested to change the password after the initial log-in.

### 3. Set up the device.

After logging in successfully,

- 1 specify Sample rate in Global Settings tab. The value should be the same as that of Dante flow.
- 2 add audio conversion sessions in related tabs and specify settings for your tasks.
- 3 set audio mixing matrix in the Matrix tab.  
Note: The AoIP channels will not appear in the Routing matrix if the source/sink has NOT been added and enabled.

### 4. Download and launch Dante Controller software from Audinate official website, and then specify parameters and routing matrix for Dante flows.

## 4. Warranty

The duration of the free limited warranty is two (2) years for the Pro Convert family and one (1) year for the accessories. For detailed warranty information, refer to [www.magewell.com/quality-assurance](http://www.magewell.com/quality-assurance)

This guide is for reference only and does not constitute any form of commitment. Products and product features (including but not limited to color, size, screen display, etc.) are subject to change without notice and are as found on the actual product.

## 5. Technical Support

If you have any problems using Magewell products or need more technical information, please submit your questions in the online Ticket System ([tickets.magewell.com](http://tickets.magewell.com)).

## Subscribe and Like Us!



Magewell



Magewellcn



Magewellcn



Magewell

MAGEWELL®